

## TECHNICAL DESCRIPTION

### SOLNA C800



## *Contents*

<b>Solna C800: Technical features in short .....</b>	<b>5</b>
SOLNA C800.....	5
Standard features:.....	5
Optional equipment:.....	6
<b>Printing Units .....</b>	<b>8</b>
Standard features.....	8
Optional equipment.....	9
Solna bearerless press concept – a concept for highest print quality .....	9
<b>Roller Diagram.....</b>	<b>10</b>
<b>Folder F840.....</b>	<b>11</b>
Standard features.....	11
Additional equipment.....	11
<b>Drive and Control System .....</b>	<b>12</b>
Drive System.....	12
Solna Printing Process Control, standard features .....	12
Solna Printing Process Control , optional features.....	12
Solna Operating Console DPC III.....	12
<b>Electrical System.....</b>	<b>13</b>
<b>Dampening water and additives .....</b>	<b>14</b>
General recommendations.....	14
Restricted substances in the dampening water .....	14
<b>Operating conditions.....</b>	<b>15</b>
Ambient air temperature .....	15
Humidity .....	15
<b>Installation .....</b>	<b>16</b>
Floor preparation.....	16
Floor loading.....	16
Compressed air installation .....	16
Water installation .....	17
Gas installation.....	17
<b>Technical Data Printing Units and Folders .....</b>	<b>18</b>
Folding possibilities .....	19
Product Sizes.....	21
Folding accuracy for Solna Folder F840.....	21
<b>Press Layouts.....</b>	<b>22</b>
16pp - Standard Single Line.....	22
32pp - Dual press line parallel with mirror-imaged printing units .....	23
32pp - Dual press line in-line with mirror-imaged printing units to the right .....	23
32pp - Dual press line with directly stacked printing units .....	23
48pp - Triple press line with one standard line and one parallel stacked line .....	23

## **Solna C800: Technical features in short**

### **SOLNA C800**

- Circumference: 578 – 630 mm (further circumferences on request)
- Min. Web-width: 420 mm
- Max. Web-width: 980 mm
- Max. geared speed: 45.000 rph
- Standard stock weights: 30 – 160 gsm (240 gsm with sheeter)

### **Standard features:**

- Festoon Splicer
- Infeed unit with integrated web guide
- Four Printing units
- Refrigerated dampening water circulation system
- Two Web severer and clamping device
- High Velocity 8m hot air dryer
- 4 drum Chill Roll stand
- Combination Web Guide and Silicon application unit
- Superstructure
- Combination Jaw Folder F840, standard equipment
- Plate punching and bending machine
- Automatic colour-to-colour register control for one web four colour
- Automatic cut-off register control for one full web
  
- SOLNA PPC:
  - 2 Operating consoles
  - Remote control of inking unit, dampening unit and register
  - SOLNA shaftless drive system

**Optional equipment:**

- Flying Splicer
- Reel handling system
- Blanket washing device
- Solna Web catcher
- Ink supply system
- Hot Air Dryer with integrated afterburner
- Desk illumination
- Cross lead for parallel presses
- Plough folder
- Rotary Cutter
- Rewinder
- Sheeter
- Longitudinal gluing device
- Compressed air unit
- Chilling unit
- SOLNA PPC:
  - Online data transmission (CIP-link)
  - Plate scanner

## Printing Units

### Standard features

- Left-hand printing units
- Cast iron, precision machined, box type side frames
- Narrow gap blanket cylinders in solid steel, nickel plated with reel type blanket lock-up
- Plate cylinders in solid steel, nickel plated with slot (no tool) plate lock-up
- Semi-Automatic Plate Change: Automatic plate cylinder positioning for plate change and automatic plate lock-up mechanism
- MultiRange eccentric system with play-free, multiple-row, bearing system and adjustable printing impression during run
- Motorized and remote-controlled circumferential and lateral plate registers
- Plate cocking device (diagonal register)
- Precision film metering inking system with three ink form rollers and three oscillating rollers, one ink form roller oscillating
- Washing-up device for each ink train
- Conventional three-roller-film dampening system for alcohol and alcohol reduced dampening with adjustable bridge roller for indirect or direct dampening
- Separately operated remote-controlled ink and dampening roller on/off movement
- Motorized, individually operated ink fountain rollers
- Motorized, remote-controlled ink fountains, 32 segments
- Touch Screen Unit Control station with all important functions available at the printing unit
- Guide roller for the entry at the first printing unit
- IR -web break detectors
- Bustle wheels
- Safety guards according to European Union Safety regulations (CE)
- Independent drive on each printing unit
- Automatic Colour-to-colour-register system for one web four colour

### Optional equipment

- Right hand printing units
- Stacked printing units
- Spray dampening system
- Blanket washing device
- Paper guide rollers below and air bars above printing units for different web leads
- Semi-automatic web threading device
- Automatic ink supply system
- Solna Web Catching device

### Solna bearerless press concept – a concept for highest print quality

- Higher rigidity through conical shaped cylinders
- Hydraloc: precision three-point hydraulic cylinder position locking device ensures no play between excentrics and side frame
- MultiRange - System: Impression adjustment on-the-run compensates different paper thicknesses through simple wheel-turn: perfect dot transfer due to real **true rolling**
- No deteriorating effects on print quality due to wearing bearers
- No risk of sudden bearer fracture, continuous bearer wear breaking or replacement



## Roller Diagram

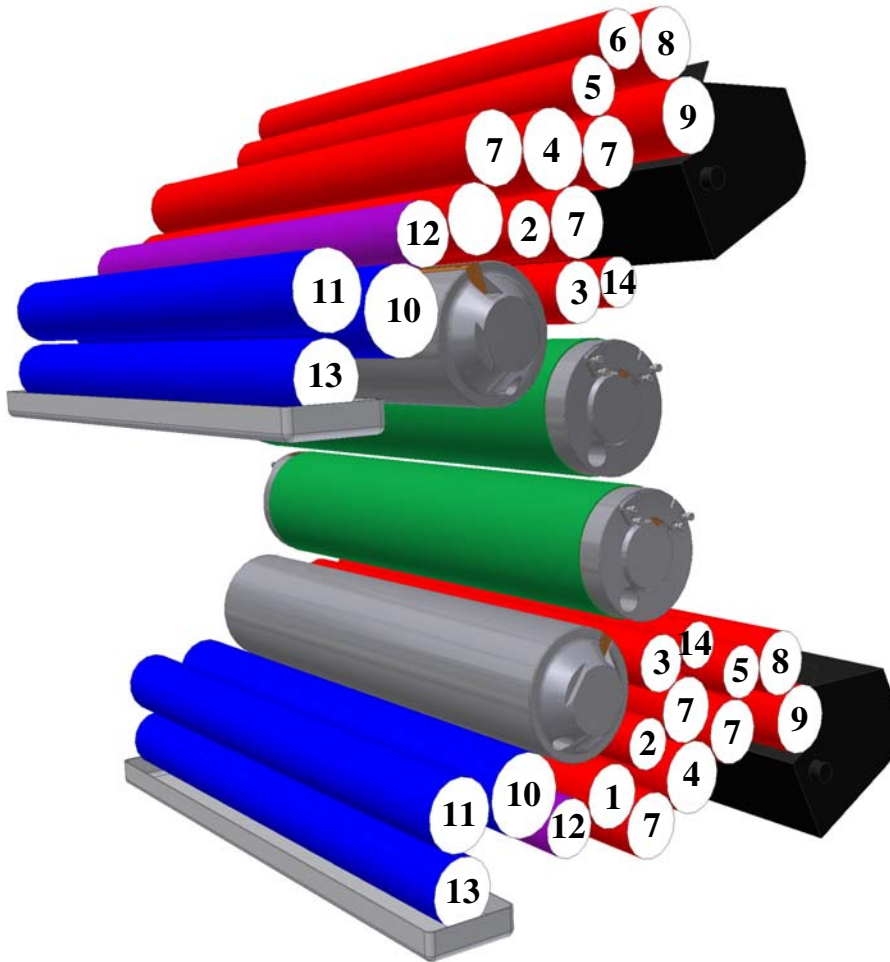

Roller Nr.	Denomination	Cover Material	Diameter, Ø (mm)
1	Plate Inker	Rubber	86
2	Plate Inker	Rubber	70
3	Plate Inker	Rubber	78
4	Ink Transfer Roller	Rubber	100
5	Ink Transfer Roller	Rubber	75
6	Ink Transfer Roller	Rubber	75
7	Ink Oscillator	Steel plasticoated	90.5
8	Ink Feed Roller	Steel plasticoated	92.51
9	Ink Fountain Roller	Steel	100
10	Plate Damper	Rubber	109
11	Film Transfer Roller	Steel crome-plated	95
12	Bridge Roller	Steel plasticoated	78
13	Water Fountain Roller	Steel plasticoated	90.2
14	Rider Roller	Steel plasticoated	65

## **Folder F840**

### **Standard features**

- Combination jaw folder mechanism, 1:2:2(:1), maximum 2 webs
- Folder superstructure with lead rollers, draw rollers and motorised cut-off compensator for one full web
- Individually drive RTF roller with pneumatically operated nip rollers and slitter/perforator wheel
- Conventional positioned long former with air in former bars and nose including blower
- Pneumatically operated nip rollers below former
- Longitudinal perforation device for the spine of the quarter fold product
- Cross perforation device for the head of the quarter folded product
- Quarter folding mechanism with automatic timing of the folding blade
- Signature overlap adjustment on the run
- Optic anti-jamming device and web severer
- Delivery table with variable speed control for to set spine separation distance
- Safety guards in accordance with the European Union Safety regulations (CE)
- Automatic Print-to-cut-Register for one web

### **Additional equipment**

- Integrated two-ribbon angle bar / bay window
- Folder superstructure with lead rollers, draw rollers and motorised cut-off compensator for two webs or ribbons
- Double parallel folder and perforation in the spine of a double parallel folded signature, adjustable on-the-run
- Driven longitudinal skip slitting in the head of the quarter folded signature
- Intermittent gluing system
- Softening device
- Automatic print-to-cut-register for second web or ribbon

## Drive and Control System

### Drive System

The Solna C800 has a shaftless drive system with servo drive motors of Bosch Rexroth Indramat. Each printing unit and folder as well as splicer, infeed unit and chill-roll stand are equipped with a single servo motor.

### Solna Printing Process Control, standard features

- **DPCIII Operator Console** with PC computer and software, video screen with alarm display and sequential start to run the main press functions and the remote-controlled ink fountains, plate registers and dampening systems
- **Computer Console** with PC Computer and software, message, reporting system and data storage of the press

### Solna Printing Process Control , optional features

- Pre-setting interface to connect press control system to CTP or plate reader equipment
- Console for auxiliary equipment control

### Solna Operating Console DPC III

The printing sequence control is carried out from the operator console.

The operating console has an ink key panel with a display and a surveillance monitor with the Surveillance Console Program.

If there are more than one console, two operators may change settings simultaneously.

The Solna Surveillance Console program is used for controlling and monitoring of the press.

The program can control the following:

- press modules to use for a print job
- start time and stop speed limit for the functions included in the printing sequence
- cut-off registers set-up for folder cut-off registers and cut-off registers controlled by the perfecting unit drive motor
- web severing devices and web break detectors set-up
- number of copies to print, start and reset of the copy counters
- ink and water feed curves
- inking units on/off

The following can be monitored:

- all press variables and parameters that are related to press control as described above
- alarm messages and their origin in the press
- active web break detectors
- press speed
- register settings
- ink and water fountain roller speeds
- reel brake set point values
- cylinder colours

### Working Position

The console panels can be adjusted in height and angle for to guarantee the most ergonomical working position.

## **Electrical System**

The control system consists of a PLC and PC-units on a Ethernet-network. In a printing unit the press functions are controlled from a PLC in the bottom cabinet via buses on different communication levels to remote I/O units and the drive units. The Press Master Console has the press configuration stored in a non-volatile memory. A PC is used in this console for press set-ups and supervision.

The remotely controlled ink fountain system is a part of the Solna Process and Printing Control System, which is a high precision presetting and press control function system. The plate scanner or a direct interface to the RIP or CTP for presetting of the ink zones is an additional equipment to further enhance quality and reduce make ready and waste. This system also has provisions for storing and recalling job information for repeat press runs. The system provides an electronic overnight fountain blade shut-off feature.

The emergency stop circuit consists of two independent stop channels. Only approved safety components are used. The emergency stop of the press is supervised by a safety module in the press master console.

Internal control voltage is 24 V DC.

Maintenance and fault finding can be performed remotely, directly into the press control system, via a direct internet connection interface by Solna Sweden.

## Dampening water and additives

### General recommendations

Cleaners and water additives must be proved to have a low tendency to corrode. Corrosion in an offset press is very dependent on the constitution of the dampening fluid, where a high percentage of salts implies a higher receptivity to corrosion.

The pH-value of the dampening fluid generally falls within the range of 4.5–6. In order to keep the pH-value of the dampening fluid constant, even if the amount of water additives varies, the modern water additives contain special acids and alkalines (buffering). The manufacturer's instructions for dosage must be strictly followed.

Note that, if not otherwise restricted by the printing process, the pH-value may well be over 6. In the case of nickel layered cylinders the pH-value should be over 4.8.

### Restricted substances in the dampening water

If the concentration of these substances exceeds the recommended value, the Solna warranty is not valid.

Substance	Maximal amount
Chlorides	40 mg/l
Sulphates	50 mg/l
Nitrates	20 mg/l

Note that these are the maximum values. The actual value may well be lower. Regular checks that these conditions are satisfied can significantly reduce the risk of corrosion caused by the dampening water.

**The quality of water shall correspond to the established limits in W.H.O. 1984 "Guidelines for drinking water".**

## Operating conditions

The Solna electrical equipment is designed to fulfil EN 60 204-1. Some of the most important conditions are given below:

Voltage	400VAC $\pm$ 10 %
Frequency	50/60 Hz $\pm$ 1 %
Voltage impulses	Not to exceed 1.5 ms in duration with a rise/fall time between 500 ns and 500 $\mu$ s and a peak value not more than 200 % of the rated r.m.s. supply voltage.

### Ambient air temperature

In the press room	Within + 15° C to + 40° C.
In transport and storage	Within – 25° C to + 55° C.

Power cables specified by Solna are designed for maximum +30°C ambient air temperature; ambient air temperature over +30°C requires a redesign of these power cables.

### Humidity

Within a relative humidity of 40 % to 75 %, non condensing.

If an earth fault relay is intended to be used, it should be discussed with Solna in advance.

## **Installation**

### **Floor preparation**

The floor and the system of joists, if any, must be in such condition that it is capable of carrying the loads of the press (see Floor loading below). It is recommended that a constructional engineer is engaged in order to give a statement of the floor condition. If the building is used for other activities that are sensible to noise and vibrations, the foundation of the press should be of such design that it will not transmit vibrations to the rest of the building.

The press is in its standard performance secured to the floor with grouted-in foundation bolts (floor bolts). To fit the foundation bolts in the right position, Solna delivers with each press line a complete set of jigs.

The foundation bolts shall be grouted-in with Embeco 885 cement. If some other type of cement is used, it should have the following properties:

- Crushing strength, 75 MPa/cm<sup>2</sup> (765 kp/cm<sup>2</sup>) after 28 days
- Thin consistence
- Effective penetration of concrete into recess, minimum 95 per cent
- Non-shrinking
- Unaffected by vibrations

It is recommended to paint the floor around the bolts to avoid corrosion of the metal parts in the concrete (cement).

Air-Loc floor bolts are not to be recommended for a heatset press for high print quality. If the floor is not suitable for grouted-in foundation bolts, special foundation rails (no longer available from Solna) have to be used.

### **Floor loading**

At each foundation bolt the floor structure should be capable of withstanding a load of approximately (for single print unit C800):

Static load 17 000 N (3 820 lbf) at max loaded bolt

Dynamic load 2 000 N (450 lbf) at max loaded bolt

Approximately weight 5 500 Kg

### **Compressed air installation**

Water free, dried, high pressure air shall be supplied for the operation of pneumatic parts in the printing units and folder at 7.5 – 8 atmospheres (110 – 116 p.s.i.) and in volume 1.5 m<sup>3</sup>/min (53 cub.ft/min) free air at 8 atmospheres.

### **Water installation**

A connection to the mains water supply will be needed for the water circulation system of the printing units.

According to the choice of cooling arrangements for the chill rolls and the oil cooling system a small quantity of make-up water will be needed at various points. The inlet water temperature should remain constantly at three degrees centigrade below the normal air temperature in the room.

Provision should be made in the planning of the machine room for adequate drainage for, although the modern cooling systems are often of the closed circulation type, there comes a time when considerable quantities of water may have to be drained away.

The quality of the water should be in accordance with W.H.O. 1984 "Guidelines for drinking water" limits.

### **Gas installation**

If gas is to be the chosen energy source for drying and perhaps afterburning, a fundamental point, not always appreciated, at an early enough stage, is the necessity of discussing with the gas authorities whether a sufficient supply can be made available for the intended purposes.

Allied to this is the question, better broached at the outset, what restrictions the local authorities could impose upon the exhaust emissions from a dryer, as this may have a bearing on the total quantity of gas required for drying and exhaust treatment.

Early discussions regarding the dryer are thus advisable. The analysis of the locally available gas supply must be known before the burners and control equipment can be correctly designed. The provision of gas to the intake flange of the dryer together with any necessary safety equipment rests with the purchaser.

## Technical Data Printing Units and Folders

	<b>C800 B</b>		<b>C800 D</b>	
<b>Cylinder circumference</b>	<b>578.0mm</b>	<b>22 3/4"</b>	<b>630.0mm</b>	<b>24 13/16"</b>
Max. printing length *)	568.5mm	22 3/8"	620.5mm	24 7/16"
Max. printing width	965.0mm	38"	965.0mm	38"
Non-printing length *)	9.5mm	3/8"	9.5mm	3/8"
<b>Plate Dimensions</b>				
Length **)	593.0mm	23.35"	645.0mm	25.39"
Width	1000.0mm	39.37"	1000.0mm	39.37"
Thickness	0.3mm	0.012"	0.3mm	0.012"
<b>Blanket Dimensions</b>				
Length, with bars	653.0mm	25 11/16"	705.0mm	27 3/4"
Width	990.0mm	39"	990.0mm	39"
Thickness	1.95mm	0.077"	1.95mm	0.077"
Underpacking	0.25mm	0.010"	0.25mm	0.010"
Total	2.20mm	0.087"	2.20mm	0.087"
<b>Register adjustments</b>				
Lateral plate register	±2.8mm	±0.11"	±2.8mm	±0.11"
Circumferential plate register	±2.8mm	±0.11"	±2.8mm	±0.11"
Diagonal (cocking)	±0.5mm	±0.020"	±0.5mm	±0.020"
<b>Rated mechanical speed</b>	45,000 rph		45,000 rph	
Web speed	7.2 m/s	1420 ft/min	7,8 m/s	1550 ft/min
<b>Max. production speed ***)</b>				
Tabloid fold	40,000 cph		40,000 cph	
Quarter page fold	40,000 cph		40,000 cph	
Double parallel fold	35,000 cph		35,000 cph	
<b>Maximum number of webs in the folder</b>	2		2	
<b>Overlaps</b>	Within ±10mm (±0.375") on all products			
<b>Pin distance:</b>	Approximately 7.5mm (0.3125") from cut edge			
<b>Delivery:</b>	Single direction for all products. Wide conveyor belt.			
<b>Signature stream (in direction of travel):</b>	Spine forward for tabloid and double parallel. Spine right or left, closed head forward for quarter page.			
<b>Signature stream separation:</b>	Stepless from 40 –120mm (1.5 – 4.75")			
<b>Weights</b>				
Printing unit incl. superstructure	5500kg	12100lbs.	5700kg	12600lbs.
F840 Folder incl. superstructure	8000kg	17600lbs.	8000kg	17600lbs.

The minimum stock weight per web in the press is 30 gsm. The maximum stock weight per web in the folder is 160gsm and to a sheeter 240gsm (provided the reel has a 3" core).

\*) Maximum printing length for a multi-coloured subject will vary to a limited degree according to the number of printing units used. This is a result of accumulation of minor differences in register adjustments in succeeding units.

\*\*) Plates should be square and strictly to these dimensions. The maximum allowable tolerance on length is +0 to -1 millimetre (+0 to -0.040").

\*\*\*) Speeds are valid provided no limitations are imposed by paper, ink or other printing conditions.

## Folding possibilities

The following examples are some of the finished formats from a single web.

For clarity the origin of two of the signature edges is shown in terms of a division of either the circumference (C) or the web width (W).

### From the Tabloid Fold

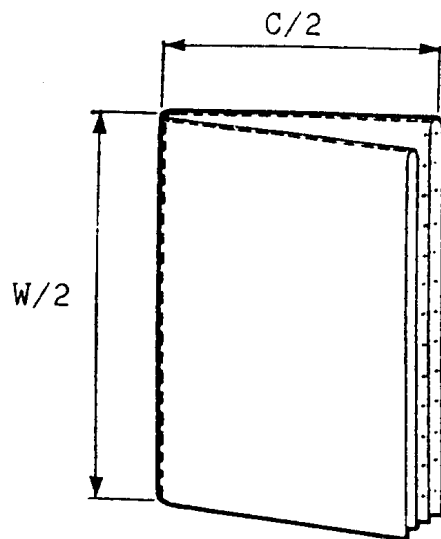

Closed head  
4 pps. Broadsheet

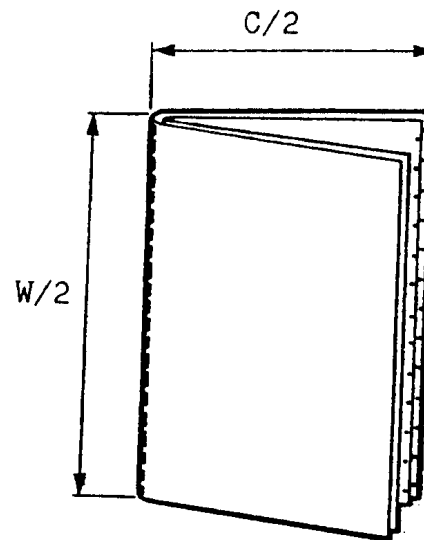

Slit over the former  
Open three side  
8 pps. Tabloid  
May be stitched

Slit and centred by angle bars  
Slit again over former  
16 pps. Landscape Magazine  
(open three sides)  
May be stitched

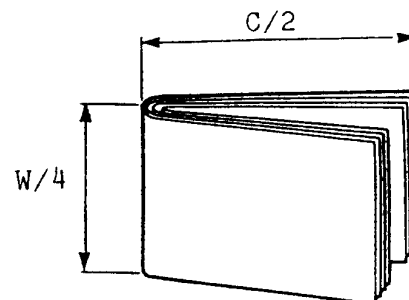

**From the Double Parallel Fold**

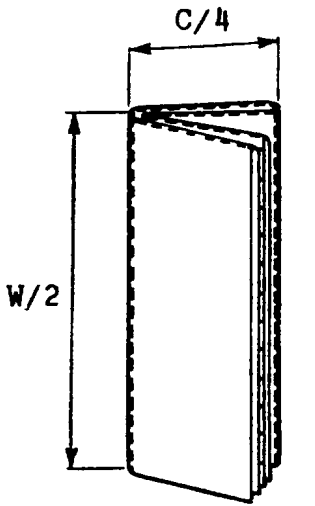

16 pps. (two-up)

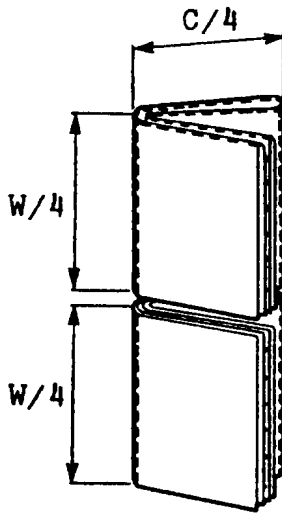

2 x 16 pps.

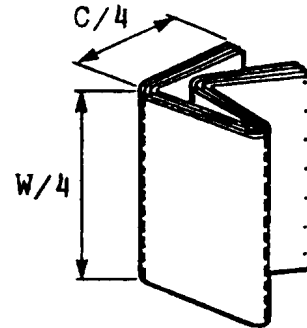

Slit and centred  
by angle bar  
Slit again over  
former  
32 pps (open  
three sides)

**From the Quarter Page Fold**

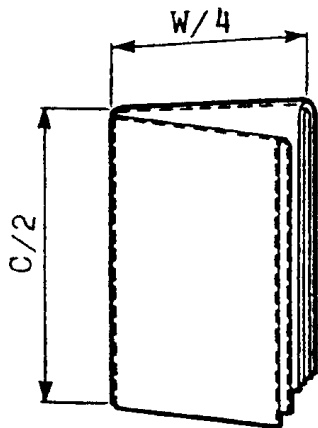

16 pps. Portrait  
Magazine. May be  
glued.

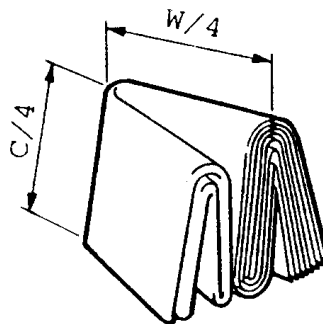

After double  
parallel  
folding  
32 pps.

## Product Sizes

The following shows the product size range for the corresponding cut-offs, without overlap.

N.B. Imperial sizes are rounded off.

		Spine		Width	
		mm	(inch)	mm	(inch)
Broadsheet	C800-B	578	(22,75)	175–490	(6,88–19,31)
	C800-D	630	(24,81)	175–482.5	(6,88–19,31)
Tabloid	C800-B	175–490	(6,88-19,31)	289	(11,38)
	C800-D	175–490	(6,88-19,31)	315	(12,38)
Quarter page	C800-B	289	(11,38)	115–245	(4,56–9,64)
	C800-D	315	(12,38)	115–245	(4,56–9,64)
Double parallel	C800-B	185–490	(7,25–19,31)	144.5	(5,69)
	C800-D	185–490	(7,25–19,31)	157.5	(6,19)

## Folding accuracy for Solna Folder F840

Tabloid products: Spine displacement  $\nabla$  0.55 mm  
Angular displacement  $\nabla$  0.30 mm

Quarter folded signatures: Spine displacement  $\nabla$  0.70 mm  
Angular displacement  $\nabla$  0.85 mm

Double parallel folded signatures: Spine displacement  $\nabla$  0.95 mm  
Angular displacement  $\nabla$  0.40 mm

*Above folding accuracy is guaranteed to be valid for 90 per cent of the samples.*

## Press Layouts

### 16pp - Standard Single Line

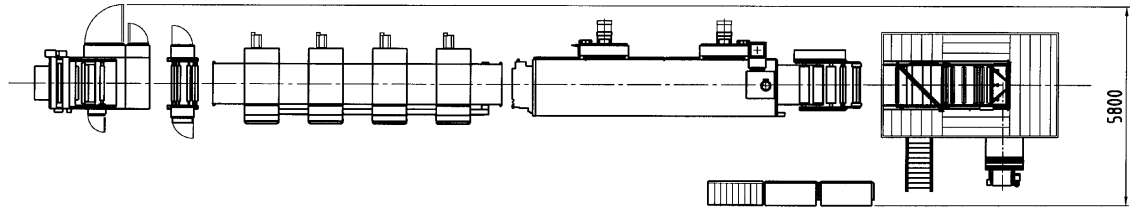
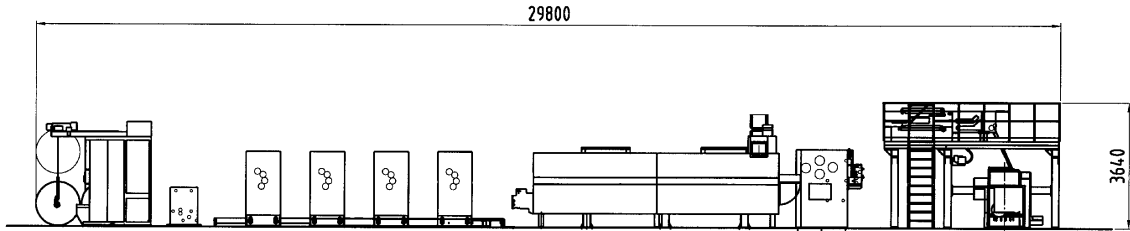

**32pp - Dual press line parallel with mirror-imaged printing units**

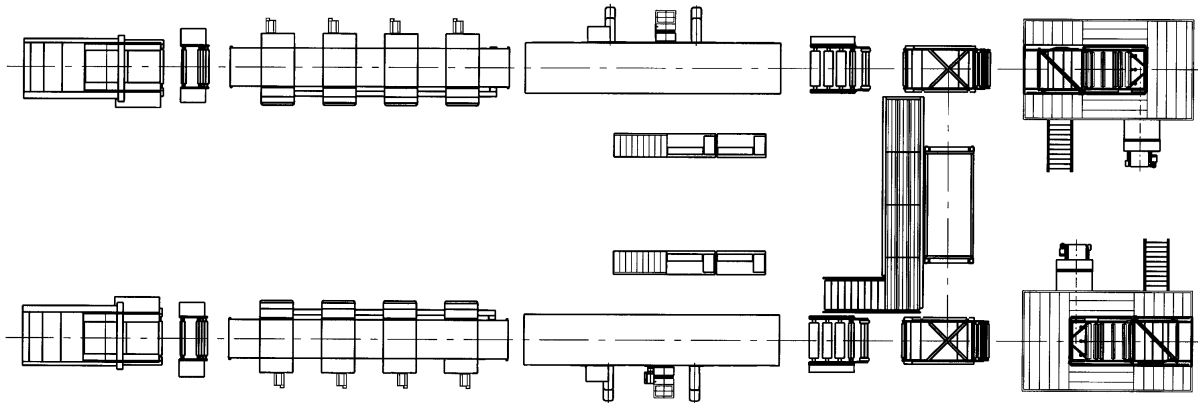

**32pp - Dual press line in-line with mirror-imaged printing units to the right**

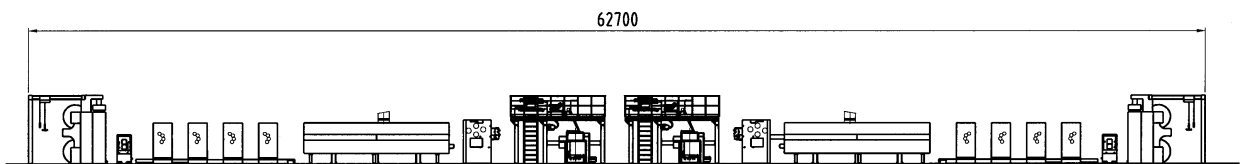

**32pp - Dual press line with directly stacked printing units**

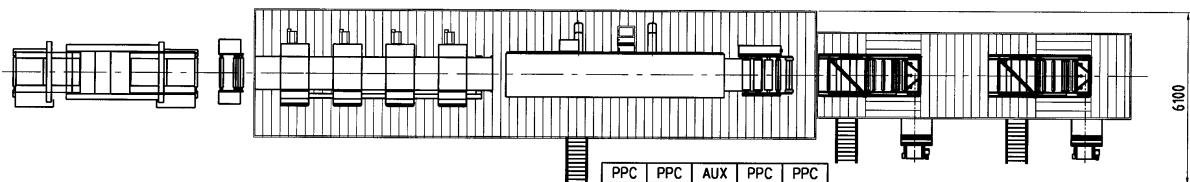
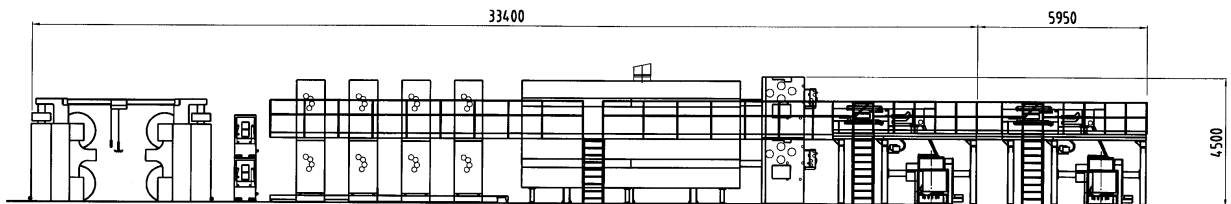

**48pp - Triple press line with one standard line and one parallel stacked line**